



Ararat Rural City

Road Management Plan

DOCUMENT CONTROL

Category Type: Plan
Type: Council
Responsible Officer: Chief Executive Officer

Last Review Date:
Date Approved:
Next Review Date:

Revision No:

Stakeholder Engagement:
Councillors
Chief Executive Officer
Internal Staff
Community



Road Management Plan 2025

1 INTRODUCTION

1.1 BACKGROUND

This Road Management Plan (Plan) defines how Ararat Rural City Council (Council) intends to manage roads and road related assets for which it is responsible.

The Plan sets inspection intervals and response times to ensure that Council's responsibilities under the *Road Management Act 2004* (the Act) are met.

In order that Council's duty of care has been satisfactorily exercised, it is required to be able to demonstrate that it has a systematic approach to inspecting roads and road related assets and has an appropriate regime for planning and undertaking repairs where defects exceeding the stated intervention levels have been identified.

Implementation and management of this plan needs to be in accordance with Council's corporate plans, strategies and policies.

1.2 PURPOSE

The *Road Management Act 2004* (the Act) has as its purpose the establishment of a coordinated management system that promotes the road network at the State and local level to provide an integrated and sustainable transport system.

Ararat Rural City Council is a coordinating road authority under the provisions of section 36(c) of the Act and the responsible road authority, for specific roads, under the provisions of section 37 of the Act.

Under Division 5 of the Act, a road authority may produce a road management plan with purposes as defined in section 50:

- a) to establish a management system for the road management functions of a road authority which is based on policy and operational objectives and available resources; and
- b) to set the relevant standard in relation to the discharge of duties in the performance of those road management functions.

2 DEFINITIONS

Terms used have the same meanings as the specified definitions used in the *Road Management Act 2004*.

For the purposes of this Road Management Plan the following terms are defined as:

<i>Act</i>	Road Management Act 2004.
<i>ancillary area</i>	An area designated as ancillary to a road includes carparks, local widening that do not form part of the road carriageway, rest stops etc.
<i>Council</i>	Ararat Rural City Council.
<i>arterial roads</i>	Major roads for which VicRoads is the coordinating road authority.
<i>bicycle lane</i>	That part of the carriageway designated for use by cyclists.
<i>carriageway</i>	The full trafficable area including the roadway and the shoulders.
<i>coordinating road authority</i>	The road authority that has overall management functions for the whole of the road reserve.
<i>Council</i>	Ararat Rural City Council.
<i>day</i>	A day on which ARCC is open for business. Where a timeframe is expressed in days it means the rest of the current day plus the number of days stated in the timeframe up to midnight on the last day.

<i>defect</i>	A localised failure within the asset which diminishes the asset's performance such as a pothole in a road, a joint displacement in a pathway, or a material failure.
<i>defect intervention level</i>	The extent of a defect that provides the trigger for maintenance repairs.
<i>hour</i>	Means one hour from the time that Council is notified regardless of whether within working hours or a day that council is open for business.
<i>intervention level</i>	The scale of the defect at which repair or remediation shall be undertaken.
<i>level of service</i>	Is a defined condition or performance standard associated with a particular asset and its classification within an asset hierarchy.
<i>make safe</i>	Temporary treatment of a defect to reduce risks associated with the defect until permanent repairs can be undertaken.
<i>month</i>	One calendar month.
<i>municipal road</i>	A road other than an arterial road or freeway for which Council is the coordinating road authority.
<i>NA</i>	Not applicable.
<i>nature strip</i>	The land, generally vegetated, between the carriageway and a property boundary or between carriageways.
<i>pathway</i>	A constructed paved, sealed or gravel path intended for use by pedestrians and / or cycles rather than motorised vehicles.
<i>Plan</i>	Road Management Plan.
<i>road reserve</i>	Crown land dedicated to the purpose of being a public highway.
<i>Regulations</i>	<i>Road Management (General) Regulations 2005.</i>
<i>response time</i>	The time for remedial works to be undertaken, following identification that the defect intervention level has been reached through routine or responsive inspections and / or following a customer request.
<i>Responsible road authority</i>	The road authority who has maintenance responsibility for all or part of the road or road assets in a road reserve.
<i>roadside</i>	The area of land within a road reserve that is neither roadway nor pathway.
<i>roadway</i>	The area of the carriageway intended for the passage of vehicles excluding the shoulder.
<i>shoulder</i>	The area between the edge of the roadway and the extent of the carriageway.
<i>temporary treatment</i>	Action taken to a defect to reduce risks associated with the defect until permanent repairs can be undertaken.
<i>verge</i>	The area of land between a property boundary and the outer edge of a kerb or a table drain.

3 SERVICE USERS AND STAKEHOLDERS

3.1 COUNCIL AS ROAD AUTHORITY

Council is the coordinating road authority for municipal roads within its boundaries with the exception of arterial roads and some roads within State and National Parks.

Ararat Rural City Council is responsible for over 2400kms of sealed, unsealed and natural surface roads

Municipal roads for which Council is the coordinating road authority are public roads available for the use by members of the public.

Within the municipality there are some roads which are managed by other road authorities.



Road Management Plan 2025

3.1.1 VicRoads

VicRoads is the coordinating authority for arterial roads. Arterial roads within the municipality are:

- Western Highway
- Glenelg Highway
- Mortlake-Ararat Road
- Ararat-Halls Gap Road
- Maroona-Glenthompson Road
- Rossbridge-Streatham Road
- Ararat-St Arnaud Road
- Pomonal Road
- Grampians Road
- Pyrenees Highway

3.1.2 Department of Transport and Planning / Parks Victoria

The Department of Transport and Planning is the coordinating authority for specific roads within State and National Parks. Some roads which are within, or pass through, Parks Victoria managed land come under the jurisdiction of Ararat Rural City Council. These are recorded in Council's Register of Public Roads. All other roads within State and National Parks are the responsibility of the Department of Environment, Land, Water and Planning or delegated entity.

3.1.3 Private road owners

Roads built on private land that are available for use by the general public are the responsibility of the landowner. The demarcation of responsibility shall be the property boundary, and where a private road enters a sealed municipal road, from the edge of the seal of the municipal road and, in the case of an unsealed road, from the outer edge of the carriageway.

3.2 INFRASTRUCTURE MANAGERS AND OTHERS

Assets belonging to other public infrastructure managers may be located below, on or above the road reserve. These can include culverts, driveways, pipelines, conduits, signs, post boxes, gates and fences, street furniture, pertaining to water supply, stormwater, sewerage, telecommunications, gas, and electricity, etc

The management responsibilities of infrastructure assets are generally detailed in the Road Management Act 2004 Code of Practice Management of Infrastructure in Road Reserves (Victoria Government Gazette 28 April 2016).

Council is not responsible for assets belonging to other managers or owners.

4 RESPONSIBILITIES OF ROAD USERS

Under the *Road Management Act 2004* all road users have a duty of care to use the road in a safe manner having regard for the existing conditions and the rights of other road users. A member of the public has the right of passage along a public road, subject to any restrictions, limitations or conditions which may be specified under any Act or law.

Posted speed limits and speed advisory signs do not designate safe driving speeds. Safe driving speeds are dependent on the existent driving conditions (rain, fog, visibility, presence of animals or stock, etc.) and existent road conditions (road surface, road alignment, road width, presence of moisture or water, pavement roughness, etc.). It is the responsibility of road users to travel at speeds that are safe with regard to existing and impending conditions. For road users such as pedestrians and cyclists, this includes



Road Management Plan 2025

maintaining an adequate awareness of surface conditions and exercising reasonable care for their own safety.

Specified roads within the municipality are pre-approved for use by higher mass limit trucks, performance based specification trucks, B-Double trucks, oversize and over mass vehicles and special purpose vehicles. It is the responsibility of drivers and operators of these classes of vehicles to obtain authorities and permits as issued by the National Heavy Vehicle Regulator, or other applicable agency, for travel on these and other restricted access roads.

5 APPLICATION OF THIS PLAN

5.1 ROAD ASSETS TO WHICH THIS PLAN APPLIES

This plan applies to all municipal roads and associated road infrastructure within the Ararat Rural City Council local government boundary and identified in the Ararat Rural City Council Register of Public Roads. This plan applies to roads added to Council's Register of Public Roads on the day following publication of notice in the Government Gazette.

5.2 OTHER COUNCIL ASSETS TO WHICH THIS PLAN APPLIES

This plan applies to other assets located within road reserves. This information is provided in summary form below. More detailed definitions of the demarcation between municipal and arterial roads can be found in the Road Management Act 2004 Code of Practice Operational Responsibility for Public Roads (Victoria Government Gazette 30 May 2017).

This plan applies to

- kerb and channel on municipal roads, and those sections of arterial roads that have parking lanes or bays for which Council is the responsible authority.
- constructed pathways on municipal and arterial roads excluding those sections of pathway that cross a central median or traffic island of an arterial road or intersection of an arterial and municipal road.
- pathways under rail-over structures.
- designated bicycle lanes within the carriageway of municipal roads.
- bridges and culverts associated with municipal roads excluding railway bridges. Refer to applicable Safety Interface Agreements with rail managers.
- traffic management devices including but not limited to roundabouts, speed humps, traffic islands, and pedestrian crossings on municipal roads.
- street signs on municipal and arterial roads excluding route information and traffic control signs on arterial roads and advance direction signs located on municipal roads that are associated with entries and exists to freeways and intersections with arterial roads.
- parking lanes and bays on municipal roads including those on arterial roads that are less than 200 metres in length and are located between kerb outstands or trees on the roadway and not intended for through traffic.
- road markings on urban and rural municipal roads. It applies to parking bay road markings on arterial roads. It includes line marking and pavement markings on roadways approaching rail level crossings including other warning markings such as rumble strips.
- stormwater drains and entry pits on municipal roads. It applies to stormwater pits on those parts of arterial roads that do not allow through traffic. It does not apply to drainage pits and underground drainage that collects run-off from through carriageways and associated junction pits in medians

on arterial roads. It applies to underground drainage that connects entry pits on arterial roads to a municipal drainage scheme.

- ancillary areas including off road public car parks managed by Council, roadside car parks managed by Council, road side rest-stops managed by Council, and other road side areas associated with tourist, historical or cultural features managed by Council.

5.3 ASSETS TO WHICH THIS PLAN DOES NOT APPLY

This plan does not apply to

- unconstructed roads or informal access tracks that are located within a government road reserve, reserved Crown land or Council owned land.
- Notwithstanding clause 5.1 above, this plan does not apply to discontinued roads from the day following publication of notice of discontinuance in the Government Gazette.
- that have been declared unused roads under section 400 of the *Land Act 1958*.
- to constructed roads, unconstructed roads or informal access tracks, including associated culverts, bridges or floodways, that are located within a government road reserve, reserved Crown land or Council owned land that provide access or entrance to a property or dwelling.
- kerb and channel on through sections of arterial roads in urban areas.
- rail bridge structures over roads.
- the structural elements of bridges over rail including guard railing attached to the bridge. It does, however, apply to the pavement and wearing surface of a pathway or road surface on a bridge over rail.
- to the structure and wearing surfaces of pedestrian crossings under rail located at railway stations. It does not apply to the structure of pedestrian crossings under rail located between stations. It does, however, apply to the pavement and wearing surface of the pedestrian crossings between stations. Refer to Safety Interface Agreements with rail managers.
- intersections with arterial roads.
- passive and active traffic management devices located within 3 metres of a rail track at a rail level crossing.
- road markings associated with traffic control of an intersection of a municipal and arterial road within and approaching the intersection.
- line marking and pavement marking within 3 metres of a rail track at a rail level crossing.
- street and intersection lighting of arterial roads. This plan does not apply to lighting of rail level crossings and pedestrian underpasses where connected to railway electricity supply.
- bus shelters and stops on municipal and arterial roads.
- all other non-road related infrastructure.

6 DEMARCATION OF RESPONSIBILITIES

6.1 GENERAL

The demarcation of responsibilities under this Plan are as defined in the *Road Management Act 2004 Code of Practice: Operational Responsibility for Public Roads* published in the Victoria Government Gazette S174 on 30 May 2017, unless specifically identified otherwise.

6.2 FREEWAYS AND ARTERIAL ROADS

VicRoads is the coordinating road authority for freeways and arterial roads and the responsible road authority for those elements of the road as defined in the *Code of Practice for Operational Responsibility*

for *Public Roads*. This is partially summarised below. There are currently no freeways within the municipality.

For urban arterial roads, VicRoads is the responsible road authority for the road pavement, kerb and channel, traffic signals, and medians. On these roads Council is responsible for the verge and footpath from the back of kerb, or the back edge of the table drain, to the property boundary. Where there are parking lanes on arterial roads that do not allow through traffic, Council is the responsible authority for the area of pavement associated with the parking lane with the demarcation being the interface of the carriageway and the parking lane. Where Council is responsible for the parking lane it is also responsible for the kerb and channel.

For rural arterial roads, VicRoads is the responsible road authority for the full width of the road reserve excluding pathways for pedestrian, cycle or shared use.

6.3 CROWN LAND

The State Government department responsible for Crown Land is the responsible road authority for specific roads, or sections of road, within Crown land including State or National Parks. In some instances these roads may be managed directly by Parks Victoria. For information about the demarcation of responsibility between the responsible department and Parks Victoria, contact the responsible department.

6.4 RAIL INFRASTRUCTURE

This plan does not apply to those sections of road, and associated traffic control devices and infrastructure, at rail interfaces that are identified in Safety Interface Agreements as being the responsibility of a rail authority. This plan does not apply to road pavement within 3 metres of the nearest rail.

6.5 UTILITIES AND OTHER INFRASTRUCTURE MANAGERS

This plan does not apply to utilities, services and associated infrastructure that are the responsibility of other road authorities or infrastructure managers.

6.5.1 Infrastructure Manager Responsibilities

The plan does not apply to infrastructure assets belonging to other infrastructure managers such as telecommunications, water and sewerage, gas, electricity, and rail (and other) transport infrastructure.

6.5.2 Private Owner Responsibilities

This plan does not apply to private roads, driveways or pathways providing access from private property to a public road.

This plan does not apply to vehicle crossings or driveways between the kerb or carriageway edge and the property boundary. These are the responsibility of the property owner to construct and maintain. This plan, does however, include the section of the crossing that forms the extension of the footpath. Council accepts responsibility for the maintenance of the footpath section of the crossing to the service levels for paths for the applicable hierarchy specified in this plan.

This plan does not apply to culverts or pipes connecting open table drains beneath driveway cross-overs.

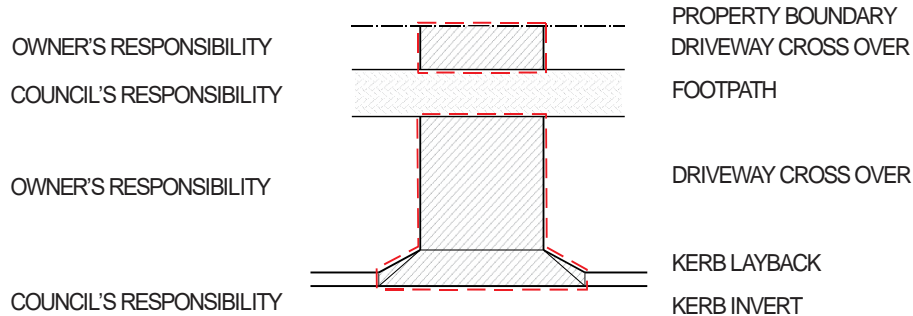

This plan does not apply to property stormwater drains constructed within the road reserve that discharge into the kerb and channel, table drain, or other stormwater collection point.

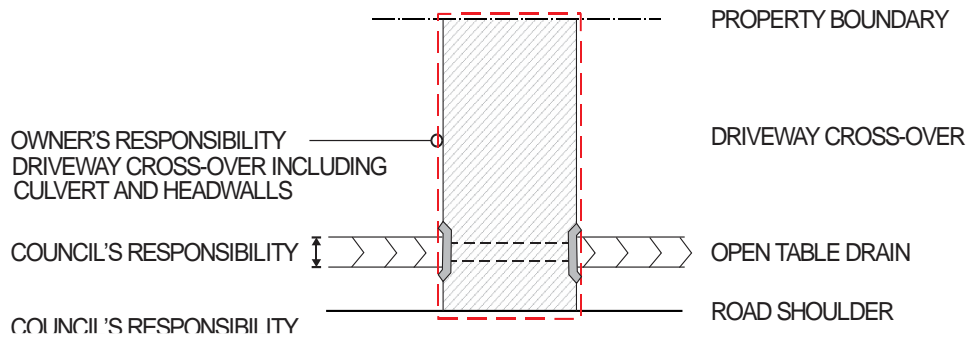

6.5.3 Footpaths and Overhanging Vegetation

The adjacent landowner has responsibility for keeping pathways clear of vegetation growing from their property. Responsibility for overhanging vegetation may be managed through Council's local laws.

6.5.4 Advertising Signage and Commercial Displays

This plan does not apply to advertising (or other) signage, shop displays or products installed or temporarily located within the road reserve, with or without permit issued under legislation or Council's local laws.

6.5.5 Outdoor Eating Facilities

This plan does not apply to outdoor eating facilities and associated furniture and hardware located or operating within the road reserve, with or without permit issued under legislation or Council's local laws.

6.6 ADJOINING MUNICIPALITIES

The *Road Management Act 2004 Code of Practice – Operational Responsibility for Public Roads* defines the basis for demarcation of boundary roads for municipal Councils.

Where the boundary of local government municipalities are defined by the centreline of a road reserve, these roads are managed under shared responsibility agreements. Generally these roads are divided into



Road Management Plan 2025

roughly equal segments which are managed and maintained by one or other municipality on the basis of negotiated agreement.

Where a municipality is defined by the property boundaries on one side of the road, the Council with the road within its boundary has operational responsibility.

Councils can agree to transfer operational responsibility for a road or a part of a road regardless of the line of demarcation.

Those road segments for which Council has responsibility are identified in the Register of Public Roads and are managed through this plan.

Those segments for which other municipalities have responsibility fall under their jurisdiction.

7 ASSET HIERARCHIES

7.1 ROAD FUNCTIONAL HIERARCHY

Urban and rural roads are assigned following hierarchies, these are summarised in the table below. Freeways and arterial roads are the responsibility of Regional Roads Victoria, with no municipal roads are assigned to this category.

CODE	HIERARCHY	DESCRIPTION
3	Sub-Arterial	Connect to or between townships. Connect townships to arterial roads. Connect to major tourist destinations. Connect to major industrial centers.
4	Collector Roads	Connect between link roads. Connect to minor tourist destinations. Connect to minor industrial centers. Connect access roads to link roads or arterial roads.
5	Local – Access Major	Provide access to one or more dwellings. Provides secondary access to urban commercial properties
6	Access Minor	Provide access to one or more properties
7	Major Track	Provide access to low use visitor sites and parks Primarily single lane and natural surface
8	Minor Track	Provide access primarily for four wheel-drive vehicles May be seasonally closed Predominantly single lane and natural surface
9	Trail	Not designed for vehicular traffic
??	Ancillary Areas	Carparks Rest areas Parking lanes

7.2 OTHER ROAD CLASSIFICATIONS

7.2.1 Urban and Rural Roads

Urban roads (U) are those roads, or parts of roads, that are within township boundaries defined by the



Road Management Plan 2025

commencement of urban speed restrictions of 60km/h or less. Urban roads may include all road types in the functional hierarchy.

Rural roads (R) are all roads, or parts of roads, that are outside of urban boundaries. Rural roads may include all road types in the functional hierarchy.

7.2.2 Sealed and Unsealed Roads

Roads may be sealed or unsealed. Within the road functional hierarchy, any road type may be sealed. Within the municipality, all link roads are currently sealed.

Sealed roads are those roads with an asphalt, bitumen and aggregate, concrete or other waterproof wearing surface.

Unsealed roads are those roads, or parts of roads, that do not have a sealed wearing surface. Unsealed roads may be formed (crowned formation with associated shoulder and table drain) with gravel pavement or natural surface, or un-formed with natural surface. Within the road hierarchy, collector roads, access major, access minor roads may be unsealed roads.

7.2.3 Right of Ways

For the purpose of this plan, right of ways on Council's Register of Public Roads are public roads. Right of ways include lanes. Right of ways generally provide secondary access (generally rear access) to dwellings and properties. Right of ways may be height and width restricted. A right of way is classified as a property access road even where providing secondary access to a dwelling. Where a right of way provides the only road access to a dwelling, it is classified as a dwelling access road.

7.2.4 Service Lanes

A service lane or road may provide dwelling or property access. These are generally roads that run parallel with an arterial road separated by a nature strip.

7.2.5 Access Tracks

Access tracks are unformed, informal routes within road reserves formed by incidental movement of vehicles. Access tracks may provide primary or secondary access to dwellings or properties.

7.2.6 Paper Roads

Paper Roads are road reserves without a physical road.

7.3 PATHWAY FUNCTIONAL HIERARCHY

PATH CATEGORY	DESCRIPTION
High Use Footpath	Paths located in or near central civic or commercial areas, or adjacent to significant community facilities such as hospitals, libraries, schools or similar.
Medium Use Footpath	Paths located in residential zones or near outer urban commercial areas or community facilities, and all paths in public parks and gardens, and recreational paths.
Low Use Footpath	Paths located in low density residential or rural living zones. Paths on roads without kerb and channel. All other footpaths.

Cycle Paths	Paths designed exclusively for cycle use. (Note distinction between bike lane which is located within the carriageway.)
Shared use paths	Paths designed to be used by both cyclists and pedestrians.

8 EXCEPTIONAL CIRCUMSTANCES – FORCE MAJEURE

While Council will make all reasonable endeavours to meet the performance standards set out in this plan, there are circumstances beyond the control of Council officers that may prevent these standards being met. Examples of these circumstances include: natural disasters such as flooding, bushfire, and wind events; breakdown of major equipment; or shortage of materials and / or labour.

In such events, the Chief Executive Officer, having considered the impacts and consequences of such events, may suspend some or all of the requirements of this plan for a period that allows for assessment and quantification of required work, for appropriate planning, for prioritisation of responses, for the allocation of resources, and for remedial work to be undertaken.

9 PLAN GOVERNANCE

9.1 PUBLICATION

This document is available to the public from the Council's website: www.ararat.vic.gov.au. This document can be viewed at the Council's office during business hours.

9.2 PLAN REVIEW

This Road Management Plan shall be reviewed in accordance with sections 8 and 9 of the *Road Management (General) Regulations 2016*. The review will be conducted so as to conclude within 6 months, following a Council election (or greater period if applicable under section 90 of the *Local Government Act 2020*) to enable coordination with the preparation of the Council Plan.

A report summarising the findings and conclusion of the review will be available at the Council office and on the Council's website in accordance with section 9(2) of the Regulations.

This Road Management Plan may be amended at any period between general elections of Council in accordance with sections 10 and 11 of the Regulations.

9.3 PLAN AMENDMENT

This Road Management Plan may be amended in accordance with sections 10 and 11 of the Regulations. Any proposed amendment to the Road Management Plan that relates to the determination of the standard of construction, inspection, maintenance or repair of the road or associated infrastructure shall provide notice of the proposed amendment in the Government Gazette and a local newspaper, identifying where a copy of the plan may be inspected, and shall allow submissions in relation to the proposed amendments to be received.

9.4 ROLES ASSOCIATED WITH PLAN GOVERNANCE

9.4.1 Manager Responsible for this Plan

The Coordinator Strategic Asset Management, or other manager as delegated by the Chief Executive Officer, shall be the manager responsible for this plan.

The responsible manager shall conduct the review of this plan. The review shall address:

- Compliance with legislation, Council Plan and other applicable Council policies
- Appropriateness of levels of service
- Errors, omissions and redundancy

The responsible manager shall consult with internal stakeholders as to proposed amendments to this plan. Where the proposed amendments relate to the determination of a standard of construction, inspection, maintenance or repair under section 41 of the *Road Management Act* 2004, the responsible manager shall issue notice of the public consultation period associated with any amendment to this plan in accordance with section 223 of the *Local Government Act* 1989 and shall summarise any submissions received from this consultation.

Where a committee responsible for asset management has been appointed, the responsible manager shall present the review of the Road Management Plan, and any proposed amendments, to the committee, for its consideration. If no committee has been appointed, the review of the Road Management Plan, and any proposed amendments shall be submitted to the Chief Executive Officer.

9.4.2 Council Committee Responsible for Asset Management

Where appointed, the committee responsible for asset management shall consider the procedures undertaken in the review of the plan and any proposed amendments to the plan. The committee responsible for asset management shall make recommendation(s) to the Chief Executive Officer in relation to the review and any proposed amendments to the Road Management Plan.

9.4.3 Chief Executive Officer

The Chief Executive Officer shall review the recommendations of the Council committee responsible for asset management, or the recommendation of the responsible manager (as the case may be), and present the recommendations, as proposed or as further amended, for consideration by Council.

9.4.4 Council

Council shall consider the review of the Road Management Plan including any proposed amendments and shall, through resolution at a meeting of Council, either; a) retain the existing Road Management Plan; or b) adopt proposed amendments to the Road Management Plan; or c) seek further amendments to the Road Management Plan.

The Road Management Plan shall remain in force until amended or revoked by resolution at a meeting of Council.

9.5 DELEGATIONS

The Chief Executive Officer has delegated the various functions under the Road Management Act and Regulations to nominated officers of Council through Council's Instrument of Sub-Delegation.

This enables Council staff to provide prompt and efficient technical and administrative response to matters under this plan.

The responsibilities and delegations identified in the Ararat Rural City Council Instrument of Sub-Delegation by CEO (as amended from time to time) take precedence over details provided in this plan.

9.6 AMENDMENT REGISTER

Issue	Date	Details
Draft	February 2025	Draft
1.0		
2.0		
3.0		
4.0		
5.0		

10 ASSET REGISTERS

Council maintains asset registers of roads, roadways, pathways, road infrastructure or road related infrastructure for which Council is the responsible road authority.

10.1 REGISTER OF PUBLIC ROADS

The purpose of the Register is to list those road assets which will be maintained by Council in accordance with this plan include information such as:

- Road name,
- Date the road became a public road (if after 1 July 2004),
- Date the road ceases to be a public road,
- Classification, if any,
- Reference to any plan or instrument that fixes or varies the boundaries of the public road (if made after 1 July 2004),
- Any ancillary areas,
- Reference to any arrangement under which management functions is transferred to or from another road authority,
- Any matter required to be included by the relevant road minister under section 22 of the Act,

A copy of Council's Register of Public Roads is available on request and for public viewing at the Municipal Offices, during normal business hours.

10.2 BRIDGES & MAJOR CULVERTS ASSET REGISTER

The register lists all bridges and major culverts for which Council is the responsible road authority. The register is held within a database and includes the following information:

- Location;
- Road hierarchy;
- Description of type.

10.3 PATHWAYS ASSET REGISTER

The register lists footpaths for which Council is the responsible road authority. The register is held within a database and includes the following information:

- Hierarchy;
- Location;
- Description of type.



Road Management Plan 2025

APPENDIX A - INSPECTION, MAINTENANCE & REPAIR

Council endeavours to identify defects that exceed the stated intervention thresholds. Where intervention thresholds are exceeded, treatment will be undertaken in accordance with the timeframes identified in the tables below for asset classes and hierarchies subject to available resources.

1 INSPECTION SCHEDULES

1.1 Roads Defect Inspection and Night Inspection

Day - Inspect for defects including potholes, seal damage or failure, pavement damage or failure, local pavement deformation, shoulder or edge damage, drainage issues, line marking, and signage.

Night - Inspect signs, reflectors and line marking for effectiveness in times of low light and poor visibility.

Responsibility - Operations & Infrastructure.

	URBAN				RURAL			
	Sub-Arterial	Collector	Local - Access Major	Access Minor	Sub-Arterial	Collector	Local - Access Major	Access Minor
Day	1 years	1 years	1 years	2 years	1 years	1 years	1 years	2 years
Night	3 years	3 years	3years	Nil	3 years	3 years	Nil	Nil

1.2 Roads Storm or Other Event Inspection from Notification

Inspect impairment associated with storm or other event.

Responsibility - Operations & Infrastructure.

1.3 Rail Crossing Inspection

Inspect for defects associated with Council responsibilities under the Safety Interface Agreement including advance advisory signs, line marking and traffic control signage.

Responsibility - Asset Management.

1.4 Bridges and Major Culverts Level 1 Inspection

Inspect for defects associated with the approaches, signage, barrier rails; super structure; sub-structure; abutments; and water way (if applicable).

Responsibility of Asset Management.

	Sub-Arterial	Collector	Local – Access Major	Access Minor	Ancillary Areas
Storm or Other Event	12 hours	24 hours	48 hours	72 hours	72 hours
Rail Crossing	2 years	2 years	2 years	2 years	N/A
Bridges and Major Culverts (Defect)	2 years	2 years	2 years	2 years	N/A
Bridges and Major Culverts (Customer request)	5 days	5 days	10 days	15 days	N/A



Road Management Plan 2025

1.5 Pathway Inspection

Inspect for defects associated with the pathway surface, obstructions, signage, hand and barrier rails (if applicable).

Responsibility - Operations & Infrastructure.

PATHS	DEFECT INSPECTION INTERVAL	CUSTOMER REQUEST INSPECTION
High Use Footpath	12 months	5 days
Medium Use Footpath	12 months	5 days
Low Use Footpath	24 months	10 days
Bike path	12 months	5 days
Shared Path	12 months	5 days

2 MAINTENANCE RESPONSE TIME

2.1 Prioritisation of Interventions

The following intervention response times apply from the time of identification by council of a defect that exceeds the stated intervention level. Identification by Council may be through proactive inspection, reactive inspection following a customer request, or other responsive notification. Where an interim response has been made, the intervention response time shall apply from the time the interim response has been completed.

Where multiple defects exceeding intervention levels are identified, intervention shall be prioritised in asset hierarchy order. Where resources are constrained (availability of funds, materials, specialist contractors or specialist equipment), the intervention response times may be extended subject to risks being reasonably managed through temporary treatment provisions.

For access major and access minor roads that are of natural surface or without formation, the intervention standard for natural surface road or track shall apply regardless of the road's hierarchy. The identification of a defect that exceeds the stated intervention level does not oblige Council to upgrade the asset or maintain the asset to a standard higher than that to which it was constructed.

RESPONSE CODE	RESPONSE MECHANISM	RESPONSE TIME
A	Inspect and rectify if possible, or provide appropriate warning, or place on maintenance program.	Within 1 business day of inspection or notification.
B		Within 2 business days of inspection or notification.
C		Within 10 business days of inspection or notification.
D		Within 20 business days of inspection or notification.
E		Within 60 business days of inspection or notification.
F		Within 6 months of inspection or notification.
G		Within 1 year of inspection or notification.

Road Management Plan 2025



Ararat Rural City

DESCRIPTION OF HAZARD	CATEGORY 4	CATEGORY 3	CATEGORY 2	CATEGORY 1
Footpath lips or trip hazards greater than 30 millimetres in height difference. Mounds or depressions greater than 100 millimetres under a straight edge. Cross falls steeper than 1 in 20.	D	D	E	N/A
Asphalt footpath affected by tree roots, lifted or depressed greater than 30 millimetres in height difference and cracked or potholed more than 20 millimetres in width and 200 millimetres in diameter respectively.				
Concrete bay is cracked or broken more than 20 millimetres in width.	E	E	F	N/A
Gravel Path potholed greater than 200 millimetres in diameter and 50 millimetres in depth and depressed by 25 millimetres.	N/A	N/A	F	N/A



Ararat Rural City

ASSET TYPE	DESCRIPTION OF HAZARD	URBAN				RURAL			
		SUB-ARTERIAL	COLLECTOR	LOCAL - ACCESS MAJOR	ACCESS MINOR	SUB-ARTERIAL	COLLECTOR	LOCAL - ACCESS MAJOR	ACCESS MINOR
Road Surface and Pavements									
Road	Size of potholes are greater than 300 millimetre in diameter and 100 millimetres in depth	C	C	D	F	C	D	F	N/A
	Edge of sealed pavement breaks or loses material and reduces the pavement width more than 200 millimetres or has a > 100 mm drop off over 20 metres of length.	E	E	F	G	D	E	F	N/A
	Shoving / Depressions or Rutting on road surface greater than 75 millimetres in depth.	F	F	F	G	F	F	G	N/A
	Corrugations should be more than 75 millimetres in depth and more than 20 metres in length	N/A	N/A	F	F	N/A	D	E	F
	Accumulation of loose materials on sealed traffic lanes	N/A	C	D	F	C	D	E	E
	Oil spill or water over road	A	A	A	B	A	A	B	C
Kerb & Channel	Vertical or Horizontal displacement is more than 100 millimetres or asset broken / displaced	F	F	G	G	G	G	N/A	N/A
Signs	Regulatory, warning and hazard signs missing, illegible at 100 metres distance or damaged, making them substantially ineffective.	E	E	E	F	E	E	F	G

Bollards and Guideposts	Bent, loose, damaged, non-functional, missing or causing injury to the general public;								
	Greater than 30 degrees off the vertical or;	E	E	F	G	E	F	G	G
Vegetation	All tree defects including intrusion into pedestrian and/or vehicle clearance zone and sight distance issues that limit clear vision	E	E	F	G	D	E	F	G
Line marking	(1)-Missing or damaged RRPM's (Reflective Raised Pavement Markers) and / or (2)- Delineation or line marking not visible or ineffective	E	F	G	G	E	F	G	G
Bridges & Major Culverts									
Bridges	In Bridges and drainage cleaning and clearing of debris from surfaces	E	F	F	F	G	F	F	F
Bridges	Any damaged or defective guardrail making it substantially ineffective					D	E	F	F